

REV.	DATE	DESCRIPTION	ISSUED SIG
A	22/11/2010	FIRST ISSUE	NJ

ITEM NO.	PART / DRG NUMBER	DESCRIPTION	QTY.
1	130-MA-20	200TDI DISCO CRANK PULLEY ASSEMBLY	1
2	130-MA-21	200TDI DISCOVERY TENSIONER ARM	1
3	130-HA-03	ELECTO-MAGNETIC 26cc PUMP ASSY	1
4	130-MD-20	200TDI DISCO ENGINE MOUNT	1
5	1440-8M-20	HIGH LOAD TOOTHED BELT	1

PRESSURE SIDE OF PUMP - HOSE TO SOLENOID VALVE

SUCTION SIDE OF PUMP - HOSE FROM TANK

4off - M10 x 40 CAP HEAD

1off - M10 x 50 CAP HEAD

1off - M10 x 30 CAP HEAD

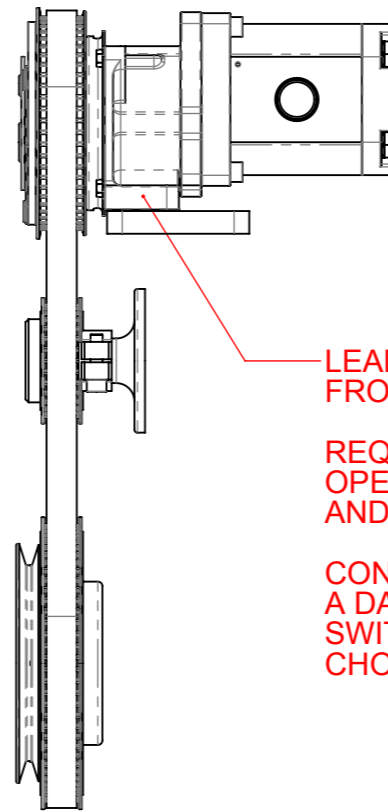
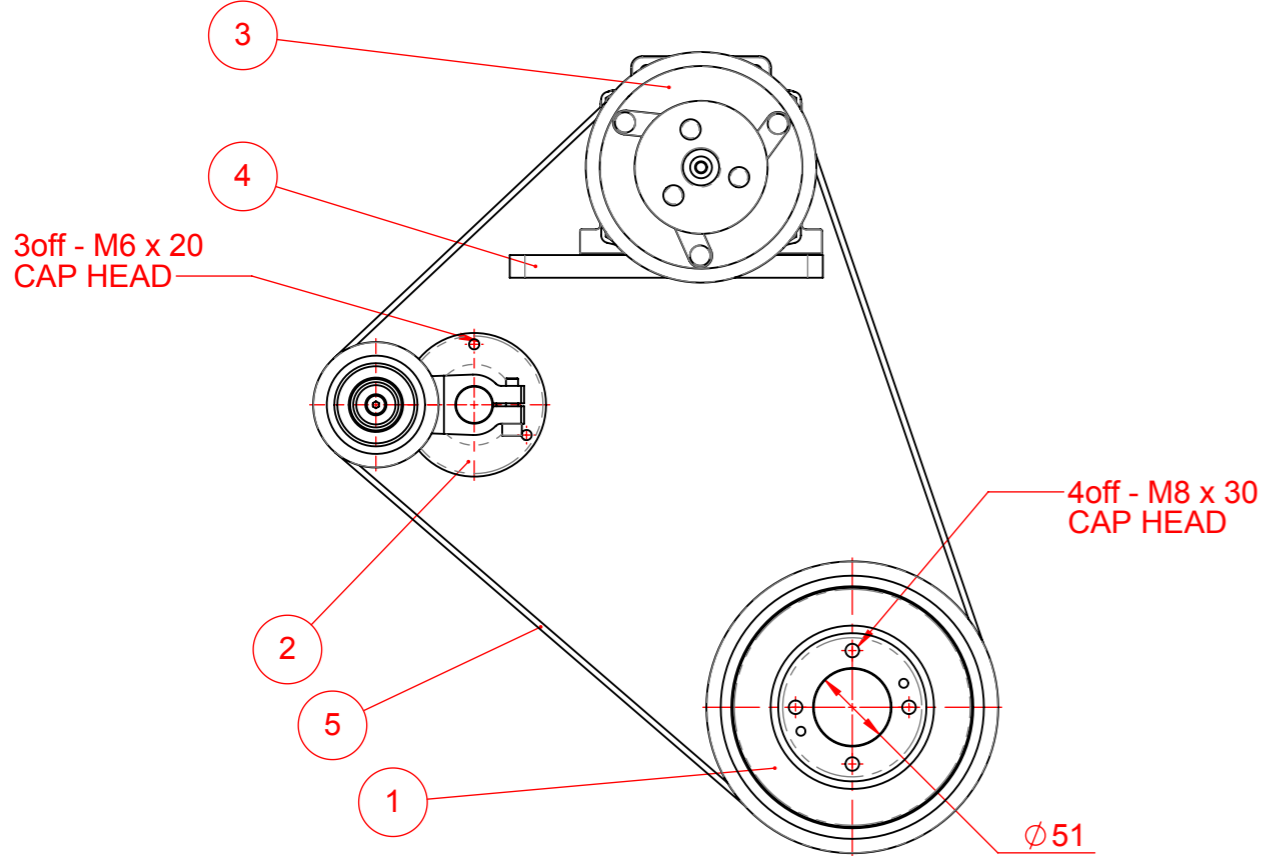
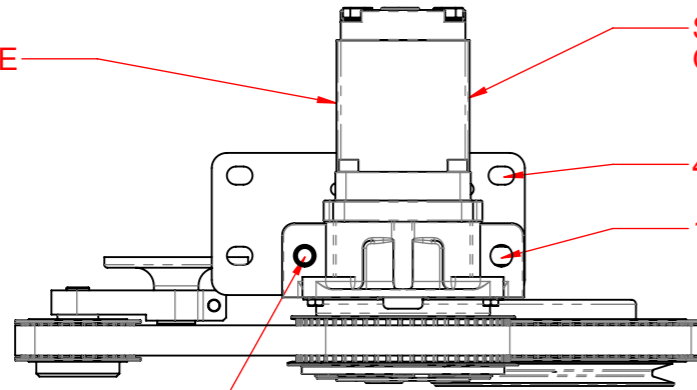

LEADS COME FROM THIS UNIT

REQUIRES 12vDC TO OPERATE MAGNET AND DRIVE THE CLUTCH

CONNECT THESE TO A DASH MOUNTED SWITCH OF YOUR CHOICE

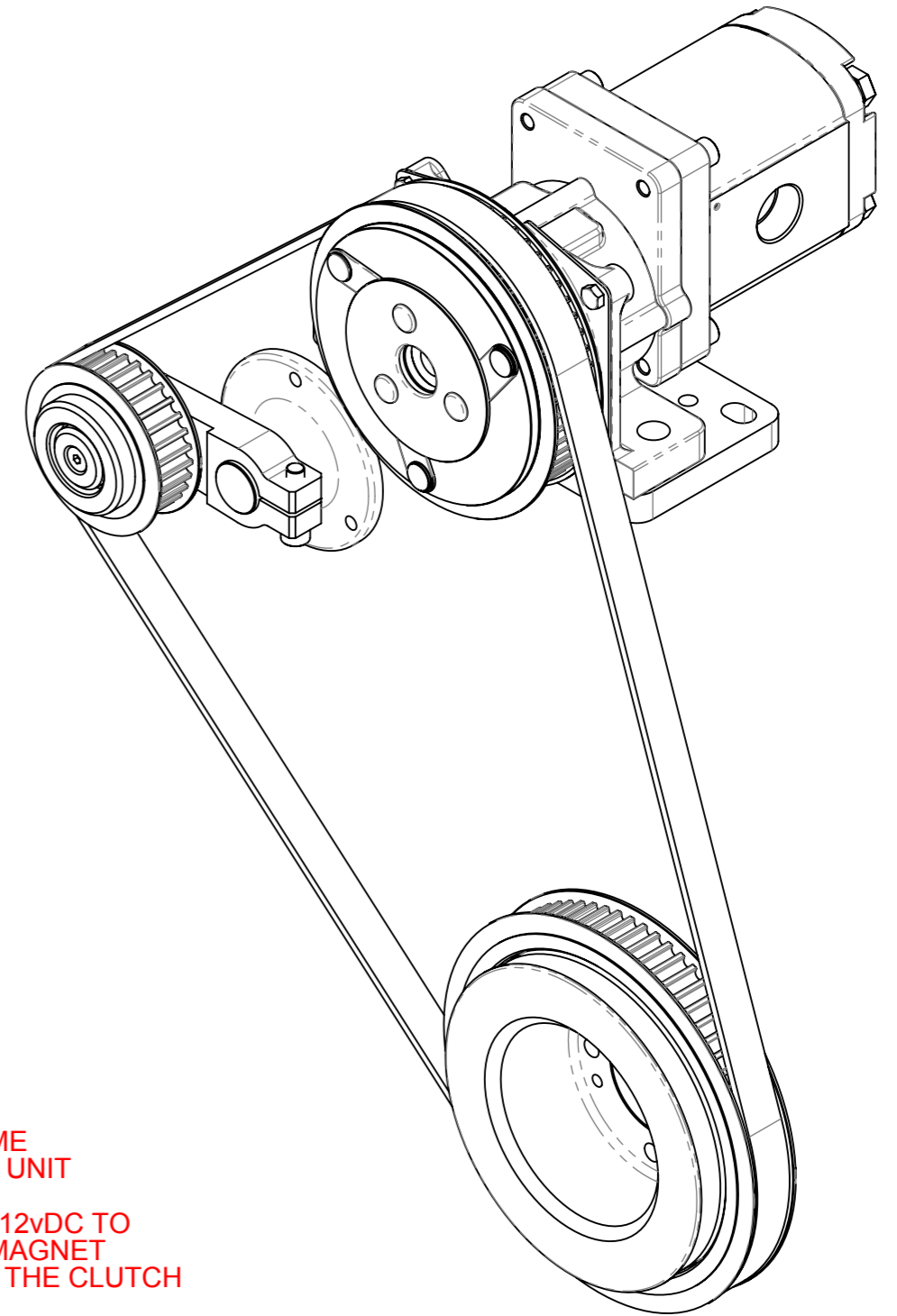

PUMP TYPE

ELECTROMAGNETIC HYDRAULIC

PUMP DESCRIPTION:

200TDI - DISCOVERY ENGINE 26cc PUMP - MAX 2500rpm

Telephone: +44 (0)1460 67744
Email: sales@red-winches.com

RED Winches

www.red-winches.com
ULTIMATE PERFORMANCE WINCH

DRAWING NUMBER:
130-MA-08

SCALE: 1:5
REVISION: A
SHT 1 OF 1

Drawing not to be reproduced or distributed in any format or method without specific permission from Redstart/Design.